

Rapida Series

Digital Speed Controller Instruction Manual

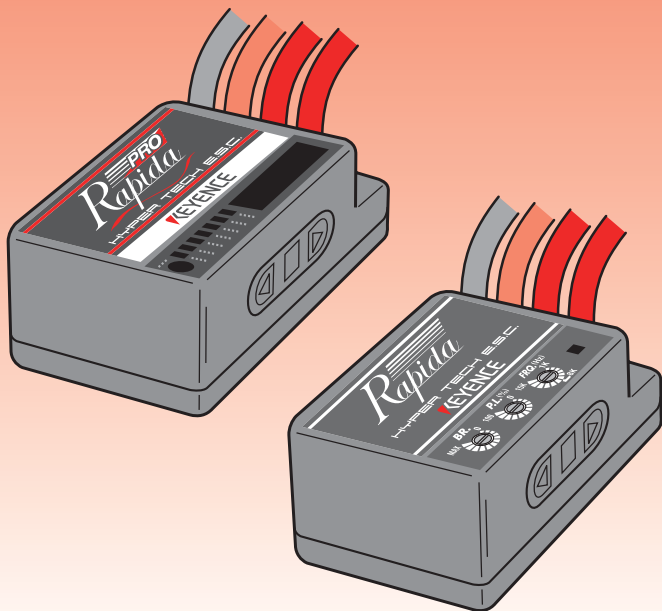

ACUVANCE

Rapida *Series*

Digital Speed Controller Instruction Manual

Precautions

Ni-Cd batteries

⚠ WARNING To avoid the risk of fumes, fire and burns

Improper use of the Ni-Cd battery is very dangerous. The battery must be handled carefully. Incorrect wiring or short-circuiting of wiring may cause fire or fumes. Before connecting or disconnecting the battery to or from the ESC, be sure to turn off the power switch of the ESC. When the battery is not in use, disconnect it from the ESC or charger, and store it in a suitable location with wires and screws removed.

Connecting silicone wiring

⚠ WARNING To avoid the risk of fumes, fire and burns

Incorrect wiring may cause fire or fumes that can damage both the ESC and battery beyond repair. To avoid the risk of accidents, do not modify wiring by yourself, even though the ESC is fitted with terminals. Take the product to KEYENCE instead.

Connecting to a motor

⚠ WARNING To avoid the risk of fumes, fire and burns

Make sure to fit the included capacitor to the motor to be used. Otherwise, the ESC may become damaged due to malfunction resulting from electrical noise.

Caution

Make sure to carefully read and understand the important warning messages in this Instruction Manual before commencing to use the product.

 **WARNING** Information for preventing serious injury

 **CAUTION** Information for preventing accidents or product damage

NOTE Useful information on handling the product

Radiating fins

 **WARNING** To avoid the risk of fumes, fire and burns

Electricity flows through the metal upper part of the ESC. Therefore, take care to avoid contacting this with conductors and other metal parts or the carbon chassis of the ESC. Take the same care even after a radiating fin is installed, since radiating fins conduct electricity.

Proper operation

 **CAUTION** To prevent accidents and product damage

Do not modify the ESC in any way. Use it only for its intended purpose. Keep the ESC away from flames or heat. Avoid splashing any liquid, such as water, on the ESC.

Features

- The RAPIDA series feature the latest MOS-FET (SOP) components, which allow powerful braking as well as a forward function.
- Advanced control circuitry using a 4-layer board that allows high-density mounting of electronic components.
- Utilizes an MPRS*1 system, which has proved very successful in the A-01 Series in large-current circuits, for compactness and high-performance.
- With AGCS*2, Schottky diodes are no longer necessary, and motor voltage loss during pulse drive is reduced to approximately 1 percent. This results in a longer run-time and prevents the heat generated by FETs.
- Smooth frequency control allows settings to be adjusted flexibly.
- AWG14 silicone cables, for flexibility and large currents
- Gold-plating is used for all electrical connectors for extremely low contact resistance.
- Outstanding energy-saving performance can be achieved by setting the power limiter function to an appropriate value.
- Includes a high-capacity state-of-the-art low impedance capacitor to minimize electrical noise.
- Improved throttle output resolution for more stable operation.

RAPIDA

- The ZERO offers 20 high-performance surface-mounted FETs that give an ON-resistance value of 0.41 m Ω (FET standard value), amongst the lowest in the world.
- You can choose four settings for brake frequency to adjust the "braking feel" to just how you like it.
- You can switch neutral brake ON/OFF.
- By setting the power limit to an appropriate value, you can drive very smoothly.
- The uses trimmer specifications for simple operation.

RAPIDA PRO

- The RAPIDA PRO offers 24 high-performance surface-mounted FETs , for an ON-resistance of 0.34 m Ω , the lowest in the world.
- With the addition of an indicator function, a variety of settings and measurement can be made easily using only the body of the ESC.
- Equipped with a variety of measuring functions for visual confirmation of optimum settings.
- Improved receiver and servo power allow the RAPIDA PRO to handle high torque servo.

*1 AGCS: Advanced Gate Control System

AGCS is a groundbreaking system that dramatically reduces losses during pulse drive by dynamically controlling FET gates (ON-OFF) according to motor speed (RPM). (PATENT PENDING)

*2 MPRS: Metal Plate Radiation (of Heat) Structure

MPRS is a hybrid structure in which current is conducted not through a copper foil on the printed board but through a metal plate, for optimum configuration of FETs.

Specifications

• RAPIDA

Power supply	6-cell NiCd battery
Maximum current	Max. current of NiCd battery
ON resistance	0.41 mΩ (FET standard)
Compatible motors	any
Dimensions	W37.4 x D27.5 x H18.0 (excl. projection)
Weight (ESC unit)	29.6 g
Regulator for receiver/servo	6V 3A output

• RAPIDA PRO

Power supply	6-cell NiCd battery
Maximum current	Max. current of NiCd battery
ON resistance	0.34 mΩ (FET standard)
Compatible motors	any
Dimensions	W37.4 x D27.5 x H18.0 (excl. projection)
Weight (ESC unit)	29.6 g
Regulator for receiver/servo	6V 3A output

Part names and wiring

Part names

• RAPIDA

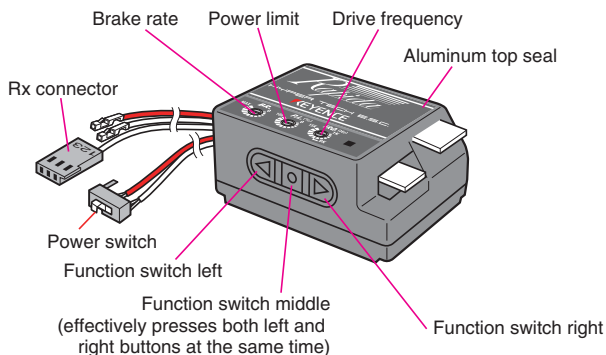

• RAPIDA PRO

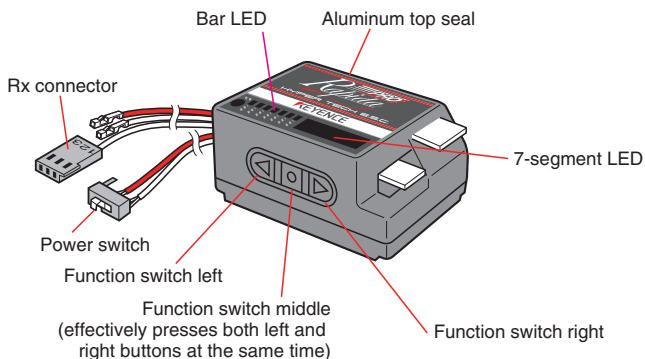

Wiring

⚠ WARNING To avoid the risk of fumes, fire and burns

Take care not to make mistakes with battery polarity. Also, make sure to connect the included noise-suppression capacitor to the motor. If not, you may damage the ESC.

• Using connectors

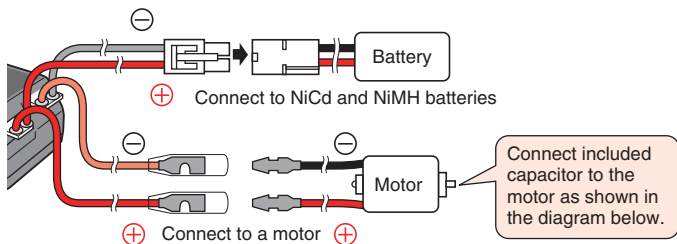

• Without connectors

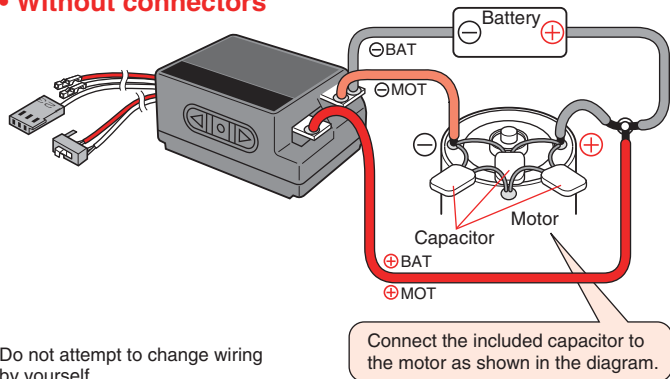

Do not attempt to change wiring by yourself.

Part names and wiring

Rx connector



⚠ WARNING To avoid the risk of fumes, fire and burns

Do not change wiring before disconnecting the NiCd battery. Also, take care not to make mistakes with the polarity of wiring, otherwise you may damage the ESC, receiver or servo. Take particular care of the servo and receiver since these cannot be repaired by ACUVANCE.

Insert the Rx connector pin according to the directions of the maker of the receiver you are going to use. Connect carefully, making sure to properly orient connectors to secure the connector pin.

Connecting cables incorrectly or inserting connectors in reverse may cause damage to the servo and receiver.

If you use a receiver manufactured by a maker other than the manufacturers listed above, contact your distributor or ACUVANCE.

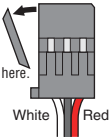
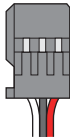
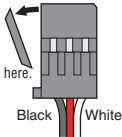
Receiver manufacturer	Old SANWA Old KO	FUTABA New KO	New SANWA (Z connector) JR
Shape of connector insert port (receiver side)	Take care not to insert in reverse. 	No need to change it. 	Take care not to insert in reverse. 
Wiring	 Cut here. White Red		 Cut here. Black White

To lock connection, the connector has barbs inside. (Not on the metal contacts.) When you pull cables out of the connector, you should lift the connector's lip by using sharp point like cutter or needle and pull out. When you insert, you should turn its concave side up and push it to the depth of "snap".

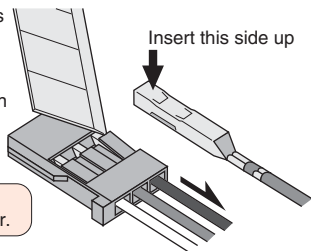

CAUTION

Be cautious when you handle needle or cutter.

Rapida 

Setting up Functions

Transmitter settings



WARNING

Before performing settings for each function, make sure to disconnect the motor or to keep the vehicle suspended in the air.

- 1 Press the left and right function switches together for four seconds.



- 2 Red and green LED blink.



- 3 Set transmitter to the neutral position and press the right function switch.



- 4 Green LED blinks.

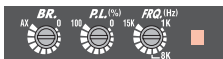

- 5 Set transmitter to the high point position and press the right function switch.



- 6 Red LED blinks.



- 7 Set the transmitter to the brake high point position and press the right function switch.



- 8 Settings are complete and the red and green LED blink at the neutral position.

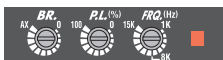

- 9 As you grip the throttle, the LED goes off once, then the green LED turns on at the high point position.

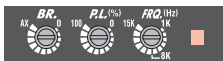

-
- 10 When you adjust the throttle to the brake side, the LED goes off once, then the red LED turns on at the brake high point position.
-

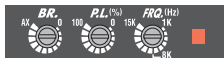

Brake frequency settings

- 1 Press the left function switch for four seconds.



- 2 The display passes through four stages from the turning off of the green LED to the turning on of the green LED, according to the current brake frequency.



Set the frequency you want by using the right function switch.



- 3
- | Frequency | Green LED | Brake feel |
|-----------|-----------|------------------------|
| 2 kHz | Off | Strong brake operation |
| 4 kHz | Blinking | Slow |
| 6 kHz | Blinking | Fast |
| 8 kHz | On | Smooth brake operation |
-

- 4 If you press the left function switch the frequency is set and recovered.



Setting up Functions

Neutral brake settings



WARNING

Before performing settings for each function, make sure to disconnect the motor or to keep the vehicle suspended in the air.

- 1 Turn off the ESC power switch once.



- 2 Turn on the power switch while pressing the right button.



- 3 The neutral brake is ON when the ESC returns to normal operation while the red LED is blinking.
The neutral brake is OFF when the ESC returns to normal operation while the green LED is blinking.



Red LED
= ON

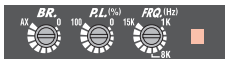

Green LED
= OFF

- 4 By repeating this same action, the neutral brake switches ON and OFF in turn.
- 5 Since the mode is registered, there is no need to reset it.

Frequency adjustment function

NOTE

Trimmer can only rotate 240 degrees.
Do not try to force it more than this.

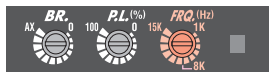

Frequency
adjustment trimmer

- You can adjust the frequency from 1 kHz to 15kHz, according to the "feel" you desire.
- For full-torque driving, set the frequency to a rather low value.
- For smoother driving, set the frequency to a higher value.
- By changing the position of the trimmer, the frequency changes to linear adjustment, allowing more detailed settings.

Power limit adjustment function

NOTE

Trimmer can only rotate 240 degrees.
Do not try to force it more than this.

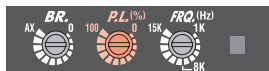

Power limit
adjustment trimmer

- By adjustment the power limit, it is possible to drive on slippery surfaces and to extend the run-time of the vehicle.

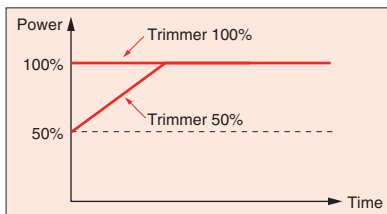

- The higher the power limit value (closer to 100%), the higher the electric current that flows in the motor.
- Lowering the trimmer value effectively controls the starting up power and the level of traction. Lowering the trimmer value also extends the run-time.

Setting up Functions

Dash power mode

NOTE

If the ESC is subject to electrical noise, there is a danger that the noise is interpreted as the first throttle action, thereby deactivating dash power mode by mistake.

This function can be used to override the power limit for the first throttle action at the time of starting up. This allows faster starting up.

1. Turn the transmitter switch on and press the left and right function switches together for four seconds.
The LED then starts blinking. (Same as setting mode.)



2. Lift your hand from the function switch and wait until the LED stops blinking. (For 10 seconds) LED blinks red and green in turn. The ESC is then in dash power mode.

Brake rate adjustment function

NOTE

Trimmer can only rotate 240 degrees. Do not try to force it more than this.

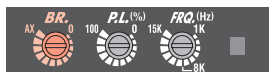

Brake rate adjustment trimmer

Driving can be made smoother by setting the brake adjustment value according to the specific road conditions.

- Adjusting the brake rate can result in higher torque braking.

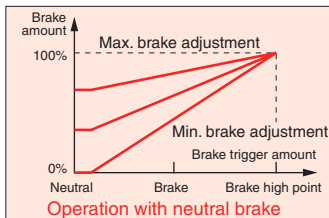
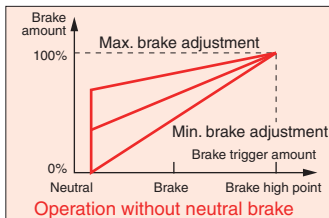

When in normal operation (no neutral brake), the minimum brake value can be adjusted by changing the brake adjustment trimmer. At the minimum setting, the brake value changes linearly according to the trigger value. As the setting reaches a maximum, the minimum brake value changes up to about 70% of the maximum brake value. If you need stronger braking than this, set to the appropriate value by gradually increasing the setting from the minimum value.

Energy Saving Mode (Abbrev. EnSA)

1. Turn off the amplifier power switch once.
2. Press and hold the left button while turning on the power switch.



3. If the unit returns to normal operation with the red or green LED flashing, the Energy Saving Mode is on. If the unit returns to normal operation with the red or green LED illuminated, the Energy Saving Mode is off.
4. Repeating steps 1 and 2 turns the neutral brake on and off alternately.
5. The mode once set is stored in memory, so you don't have to set the same mode again.

		Energy Saving Mode	
		ON	OFF
Neutral Brake	OFF	Green flashes	Green ON
	ON	Red flashes	Red ON
Energy Saving Effect		Great	Small
Motor Noise		High	Low

The Energy Saving Mode should generally be turned on, but turning off the Energy Saving Mode may help achieve more stable performance, depending the type of motor and its degree of deterioration. If the motor has deteriorated, turning off the Energy Saving Mode enables more stable operation.

Malfunctions caused by noise may be avoided with the Energy Saving Mode turned off.

Various Settings

Output on transmitter handle is shown in the graph below.
(with neutral braking)

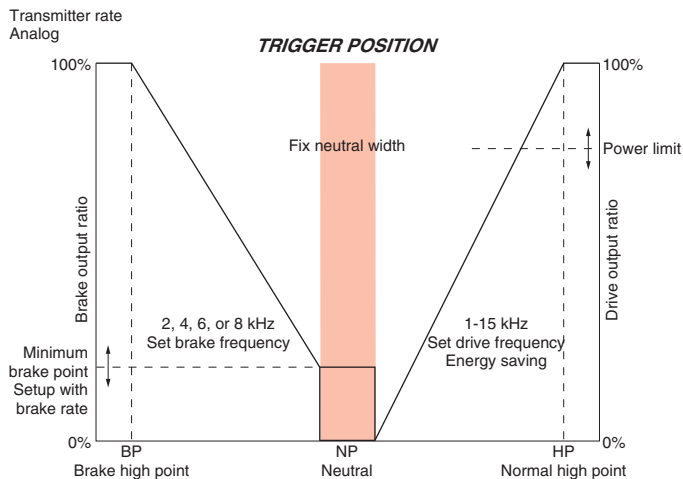

1. For full-torque driving, set frequency rather low, to around 1.0-2.0 kHz.
2. For smooth driving, set frequency rather high, to around 8.0-14 kHz.
3. As you increase frequency, driving is smoother but the amount of heat generated in the electric circuitry increases. When using a high-powered motor, we recommend that you limit the frequency of the drive brake to 10 kHz.
4. The energy-saving circuit is particularly effective for driving at low and medium speed. However, effectiveness depends on the type of motor, gear ratios and drive frequency. If the drive frequency is too low, the energy-saving circuitry does not work well. On the other hand, if the drive frequency is too high, the loss due to internal heat generation becomes too high. So, generally, the frequency range for energy-saving is around 3.0-12.0 kHz, according to the settings for the vehicle.
5. For frequency settings, if the starting speed torque is not high enough, increase the value of minimum drive power.
6. If the brake doesn't work well, increase the value of minimum brake power.

PRO
Rapida

The logo consists of the word 'PRO' in a bold, italicized, sans-serif font, positioned above the word 'Rapida' in a cursive script. A large, stylized 'P' is on the left. A red triangle points to the right, overlapping the 'PRO' and 'Rapida'. A grey swoosh is at the bottom.

Function Indicators (settings are explained from page 20)

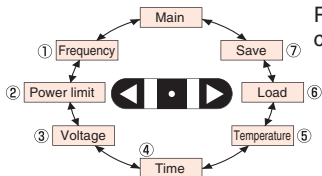

Pressing the left or right function switch changes the display on the indicator.

(Hereinafter, "switches" shall mean the function switch on the main body.)

The items displayed by the 7-segment LED are as follows.

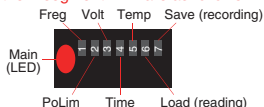

1 Main Display

This indicates the current output as a percentage. (The display changes automatically according to the change in the number of LED bars displayed.)

LED main, red lamp is on.



n...neutral

Normally displays 0P (percent); current value is displayed when adjusting the neutral brake setting.



d...drive

Displays values up to 100P (percent) according to the change in the LED bars



b...brake

Displays values up to 100P (percent) according to the change in the LED bars.

2 Frequency (F.R.Q.) display

Displays currently set frequency in kHz.

LED (1) is on.



Fd...drive frequency

Displays values between 0.1 and 20.0 (100 to 20000 Hz).



br...brake frequency

Displays values between 0.1 and 20.0

3 Power limit (P.L.) display

Displays current power limit value.

LED (2) is on.



Displayed values are in units of %.

*The higher the value, the greater the current flowing.

4 Battery voltage (VOLT) display

This indicates the current value of battery voltage (units VOLT). (The value is higher before driving; lower after driving.) This value can be used as a yardstick to assess battery condition. If this value remains low even after recharging, the battery is effectively dead.

LED (3) is on.



Yardstick voltage values when using 7.2 V NiCd and NiMH

(8 V or higher) High	Battery can be effectively used.
(6.8 V or lower) Low	Battery is depleted or dead.

5 Measuring time (TIME) display

This indicates the amount of time from the moment when power is turned ON or from the moment the trigger is pulled after reset, until the time the voltage falls to the set value. To perform a reset, press the left button and right button together for four seconds (or press the middle button.)

1. If different kinds of batteries are used in the same vehicle, these values can be used to decide which batteries have the longest running time.
2. If the same kinds of batteries are used in multiple vehicles, these values can be used to find out the influence of different settings on vehicle run-time.

LED (4) is on.



Reset by pressing this button for four seconds.



6 Internal temperature (TEMP) Display

LED (5) is on.



This indicates the current internal temperature.



By pressing this button, the display switches between units of Centigrade (C) and Fahrenheit (F).

1. The value may be affected by the road surface temperature.
2. We recommend that, as a general rule, you dissipate heat when temperature gets over 100C (210 F).

7 Program load

LED (6) is on.



This is the setting used to call up a program.

8 Program save

LED (7) is on.



This setting is used for saving a program.

Setting up Functions

1 Setting the transmitter position

WARNING Before performing settings for each function, make sure to disconnect the motor or to keep the vehicle suspended in the air.

NOTE If the position of the transmitter is not set properly, all subsequent settings may be inaccurate. So, take care to set up the transmitter properly.

When the display is in the main mode, press the left and right buttons on the sides of the main body at the same time. You can then perform a variety of settings by switching the displays using the left button and right button.



Main LED blinks.



1-1 Setting up the transmitter

Firstly, perform settings according to the transmitter.



nutr neutral
dfHP drive (forward) high point
brHP brake high point



When in SET display mode, press the left and right buttons together for four seconds.



The display will then switch to nutr (neutral). Match the transmitter to the position of neutral, and press the right button on the side of the main body.



The display will change to drHP (drive, high point). Match the transmitter to the high point position and press the right button on the side of the main body.



The display will change to brHP (brake, high point). Match the transmitter to the high point position and press the right button.

Settings are complete and the display returns to SET display mode.

1-2 Setting neutral width

Press the right button in SET display mode.

The initial drive brake position (the position where the brake begins to take effect) can be adjusted according to the transmitter you use.



The transmitter trigger performs a count-up on the drive side and a count-down on the brake side. Set the values you want using the transmitter. When you determine the setting value, press the right button.



1-3 Setting minimum drive power

If starting up speed is slow, you can increase the initial value of the drive, up to 70% of maximum speed.

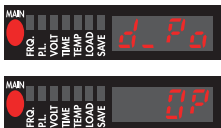

The transmitter trigger performs a count-up on the drive side and a count-down on the brake side. Set the values you want using the transmitter. When you determine the set value, press the right button.

1-4 Setting minimum brake power

If the brake does not work effectively, you can increase the initial value, up to 70% of maximum braking.

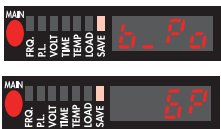

The transmitter trigger performs a count-up on the drive side and a count-down on the brake side. Set the values you want using the transmitter.

- If the initial values set for both drive and brake power are extremely high, motor output width for trigger operation on the transmitter side will decrease.
- Units used for 4-1-2, 3 and 4 are P (percent).

1-5 Neutral brake power setting

Set this when you want the brake to operate automatically when changing back to neutral.



The transmitter trigger performs a count-up on the drive side and a count-down on the brake side. Set the values you want using the transmitter.

1-6 Engine brake ON/OFF

This setting performs dummy engine braking, which effectively applies brakes according to the amount of trigger recovery of the transmitter.

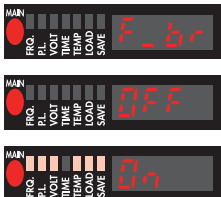

The transmitter trigger turns ON on the drive side and OFF on the brake side. Set to ON/OFF using the transmitter.

- Brake is applied according to the amount of recovery of the transmitter trigger. Press the left and right buttons together (or press the middle button) to register the setting after deciding the setting value.

Setting up Functions

1-7 Energy-Saving Mode (Abbrev. EnSA)

EnSA	100%	70%	30%	0%
Energy Saving	Maximum			Minimum
Motor Noise	Larger			Smaller
Schottky Diode	–	Required	Required	Required

* The energy-saving mode is always at 100% while engine braking is on.

The trigger of PROPO counts up at the drive side and counts down at the brake side.

The setting can be selected from the four patterns above.
Set to the desired value with PROPO.

Use the EnSA mode at 100% for normal operations.

However, adjusting the EnSA level will ensure more stable operations depending on the type of motor and its deterioration level.

When the motor has deteriorated, set the EnSA level to "0" to stabilize the operation.
When malfunctions are caused by noise, lowering the EnSA level may alleviate the problem.

When using the EnSA mode with a setting other than 100%, **attach the Schottky diode to the motor.**

(Not required at the 100% setting.)

2 Setting frequency



WARNING

Before performing settings for each function, make sure to disconnect the motor or to keep the vehicle suspended in the air.

When in frequency display mode (p18, 2), press the left and right buttons together. You can then perform various settings by switching display using the left and right buttons.



LED (1) blinks.

2-1 Drive frequency

Set to optimum "driving feel" by adjusting frequency.



The transmitter trigger performs a count-up (frequency increases) on the drive side and a count-down (frequency decreases) on the brake side. Set the values you want using the transmitter. When you determine the set value, press the right button.

Ex. Displayed values are in units of 1000 Hz.
4.1 = 4100 Hz

2-2 Brake frequency

Adjust the "feel" of applying the brake.



The transmitter trigger performs a count-up on the drive side and a count-down on the brake side. Set the values you want using the transmitter. When you determine the set value, press the right button.

2-3 Neutral brake frequency

You can set the brake value when using a neutral brake.



The transmitter trigger performs a count-up on the drive side and a count-down on the brake side. Set the values you want using the transmitter. When you determine the set value, press the left button and right button together (press the middle button).

Setting up Functions

3 Setting the power limit and dash power mode



WARNING

Before performing settings for each function, make sure to disconnect the motor or to keep the vehicle suspended in the air.

When in power limit display mode (p18, 3), press the left and right buttons together. You will then be able to perform various settings related to power limit and dash power mode by switching the display using the left and right buttons.



LED (2) blinks.

3-1 Setting power limit

When driving on a slippery road, initial torque can be decreased by lowering the value to make driving easier.

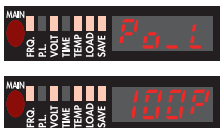

When in power limit display mode, press the left and right buttons together. LED (2) starts blinking and the display automatically alternates between Po-L (power limit) and the value (%) in turn. (Power limit setting display) At this point, you can switch between setting power limit and setting dash power mode by pressing either the left or right buttons. When power limit setting is displayed, the transmitter trigger performs a count-up on the drive side and a count-down on the brake side. Set the value you want using the transmitter. When you determine the set value, press the right button.

3-2 Dash power mode

This function raises the power limit from the first trigger action at starting time, which helps to start up quickly.

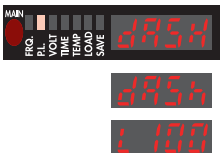

While in dash display mode, press the left and right buttons together for four seconds. You will then be in dash power mode. Check if the dash and limit value (LXXP = limit XX%) appear in turn, as shown in the diagram, when power limit display mode returns. If so, setting is completed.

- If the display shows L100P, no effect will be observed.

4 Setting voltage level for time measurement



WARNING

Before performing settings for each function, make sure to disconnect the motor or to keep the vehicle suspended in the air.

When in voltage level for time measurement, press the left and right buttons together (press the middle button). To measure time, start from the state where the trigger is pulled, then stop when the battery voltage reaches the set level. You can set the battery voltage when time measurement stops.



LED (3) blinks.

To measure time, start from the state where the trigger is pulled, then stop when the battery voltage reaches the set level. You can set the battery voltage when time measurement stops. When you have determined the setting value, press the left and right buttons together (press the middle button). Measurement stops as soon as the voltage drops below the set voltage value, even for just a moment. When the battery is running down, the ordinary voltage value of 7.2 V may drop momentarily due to motor speed fluctuation. For this reason, set to about 3-5 V.

5 Program load



WARNING

Before performing settings for each function, make sure to disconnect the motor or to keep the vehicle suspended in the air.

This function can be used to call up both initial (default) settings and custom settings.

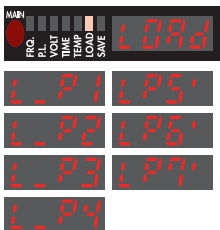

The RAPIDA PRO offers a total of seven types of programs.

You can save programs in P1 to P4 or you can call up the original (default) programs stored in advance in P5 to P7.

- Original (default) programs are listed in p15 of this instruction manual.

Setting up Functions

It is possible to load and call up an original (default) program, make a change to it, save it, and then reuse it as a custom program.

- Set by default at the factory as P5.



When in load display mode, press the left and right buttons together. LED (6) starts blinking. Then, set the number of the program you wish to load by using either the left button or right button. Then press the left and right buttons together for four seconds. When the program loading is complete, "End" will be displayed.

6 Program save



WARNING

Before performing settings for each function, make sure to disconnect the motor or to keep the vehicle suspended in the air.

You can save custom programs according to road and vehicle conditions.



Changed (custom) programs can be saved from P1 to P4.

S.P.1

S.P.2

S.P.3

S.P.4

When in save display mode, press the left and right buttons together. LED (7) starts blinking. After that, set the number of the program you wish to save by using either the left button or right button. Then press the left and right buttons together for four seconds.



When the program loading is complete, "End" will be displayed.

- Except for program mode, when you turn the power ON, all previous settings (transmitter position, frequency, etc.) are restored.

Various Settings

Output on transmitter handle is shown in the graph below.
(with neutral braking)

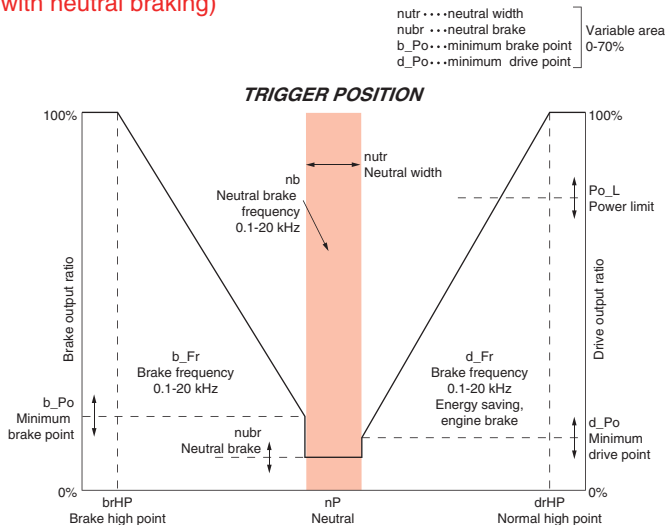

1. For full-torque driving, set frequency rather low, to around 0.5-2.0 kHz.
2. For smooth driving, set frequency rather high, to around 8.0-14 kHz.
3. As you increase frequency, driving is smoother but the amount of heat generated in the electric circuitry increases. When using a high-powered motor, we recommend that you limit the frequency of the drive brake to 15 kHz.
4. The energy-saving circuit is particularly effective for driving at low and medium speed. However, effectiveness depends on the type of motor, gear ratios and drive frequency. If the drive frequency is too low, the energy-saving circuitry does not work well. On the other hand, if the drive frequency is too high, the loss due to internal heat generation becomes too high. So, generally, the frequency range for energy-saving is around 3.0-12.0 kHz, according to the settings for the vehicle.
5. For frequency settings, if the starting speed torque is not high enough, increase the value of minimum drive power.
6. If the brake doesn't work well, increase the value of minimum brake power.
7. When you turn the engine brake ON, the speed suddenly changes to match the transmitter trigger. You can use this as you like.

Default values (manufacturer's setting values)

	P5'	P6'	P7'
Neutral width	9%	7%	5%
Minimum drive power	10%	7%	3%
Minimum brake power	10%	7%	3%
Neutral brake	0%	0%	0%
Engine brake	—	—	—
Drive frequency	1.5kHz	5.0kHz	9.5kHz
Brake frequency	2.0kHz	4.0kHz	5.0kHz
Neutral brake frequency	2.0kHz	4.0kHz	5.0kHz
Power limit	100%	100%	100%
Battery voltage for time measuring	4.0V	4.0V	4.0V

P5': High-torque setting (factory default setting)

By setting the drive frequency to a low value, this setting enhances the trigger pick-up in the low speed range.

This is a good setting to use when vehicle tires have a good grip.

P6': Standard setting

Frequency of ESC is set to a standard value that provides even performance from low to high speeds.

P7': Smooth setting

Frequency is set to handle subtle throttle work from medium to high speeds.

Installing a heat sink (radiating fin)



WARNING To prevent fumes, fire and burns

Electricity flows through the copper plates in the upper part of the ESC. If you install a radiating fin, electricity may flow through it, so do not allow other conductors or metal parts to make contact with the radiating fin.

When running a car outdoors directly under the sun, or if you are using a high-torque motor, installing a radiating fin enables more stable operation. Mount the radiating fin as described below:

1. Remove the aluminum sticker at the top of the ESC housing.
2. A metallic plate is exposed.
3. Remove dust from the plate surface.
4. Attach the double-sided tape (included) to a radiating fin (the thin tape)
5. Attach the heat sink securely to the metal plate of the ESC.

(To improve radiation, apply a 2-gel type epoxy resin adhesive instead of the double-sided tape. Knead the gels well and apply a light coat of it to the heat sink. Attach the heat sink to the metallic plate and fix them until the adhesive dries. Note that you cannot remove the heat sink once you attach it.)

Troubleshooting

Symptom	Cause
Cannot set "High point"	Improper setting of ESC
	Improper transmitter setting
	Power limit value too low
Brake fails.	Improper setting of ESC
	Improper transmitter setting
Both motor and servo do not work.	Bad contact with battery
	Improper wiring of receiver
	Receiver failure
	Transmitter failure
	ESC failure
Motor does not work but servo works.	Incorrect setting of ESC
	Motor failure
	Bad contact with battery
	Bad contact with receiver connector
	ESC failure
ESC gets too hot.	Input voltage is too high.
	Insufficient cooling
	Driving load is too high.
	Drive frequency is too high.
Reduced acceleration.	Improper ESC setting
	Power limit value is too low.
Car operates improperly.	Failure of motor capacitor
	Bad receiver position
	Transmitter/receiver failure
	Incorrect wiring

	Remedy
	Reset transmitter throttle setting to normal before setting "High point." Set "High point" position to 90% of full throttle.
	Correct transmitter throttle setting.
	Increase power limit value.
	Reset transmitter brake (reverse) setting to normal before setting "Brake high point." Set "Brake point" position to 90% of full throttle.
	Correct transmitter brake setting.
	Check that contact with battery is good.
	Check wiring of receiver and servo.
	Replace crystal or request repair.
	Replace crystal or request repair.
	Request repair.
	Setup ESC again from the beginning. (Make sure to set transmitter position accurately before doing this.)
	Replace motor.
	Check that battery and cables are properly connected.
	Check that receiver connector pins are not broken.
	Request repair.
	Use 6-cell power supply.
	Attach radiating fin to improve air flow and heat radiation.
	Adjust drive system to work smoothly.
	Lower drive frequency.
	Setup ESC again from the beginning. (Make sure to set transmitter position accurately before doing this.)
	Increase power limit value.
	Replace motor capacitor.
	Keep receiver as far from battery or ESC as possible.
	Request repair from the maker.
	Check that silicone cables are not running through the receiver side.